

This document contains the proprietary information of Tandemloc, Inc. and your access and use shall be, and is at all times, pursuant to and limited by the Tandemloc, Inc. Terms of Use. You shall not, and shall not encourage, assist, or authorize another party to copy, distribute, publicly display, modify, reverse engineer, decompile, or take any other action to reproduce this document or the information contained herein.

©2019 by Tandemloc, Inc. Dimensions are subject to manufacturing tolerance and change.

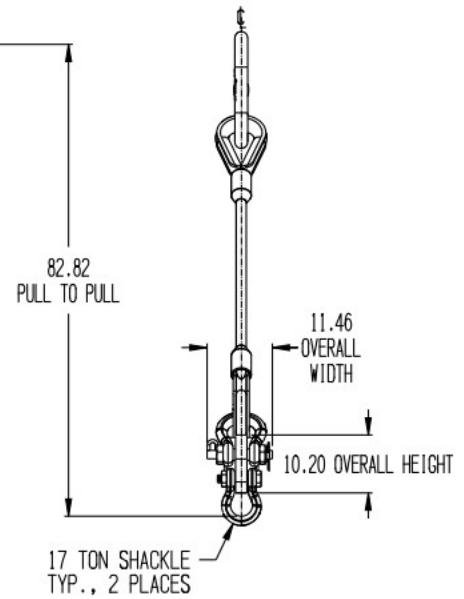
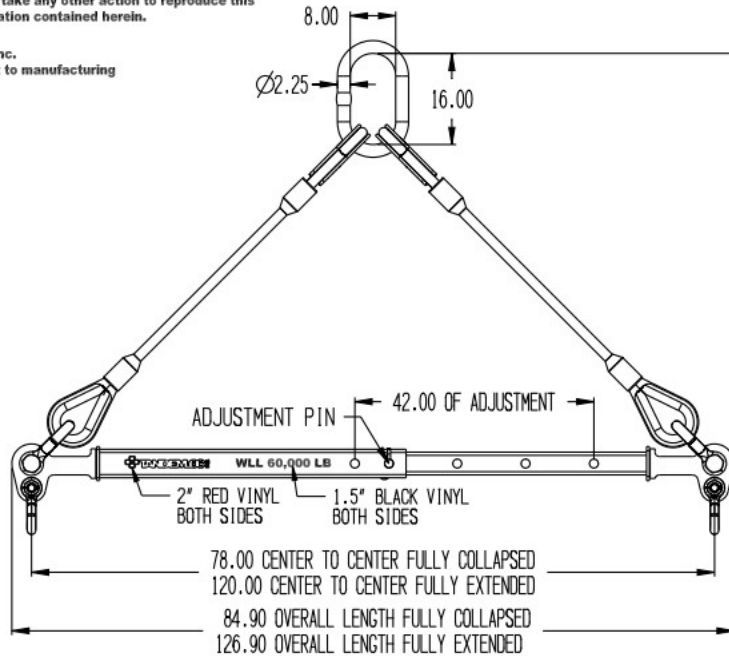

- NOTES:
- PART NO.: AT14A060-120-PA, 78"-120" TELESCOPIC SPREADER  
AT14A060-120SPA, 78"-120" TELESCOPIC SPREADER WITH TOP SLING
  - WLL: 60,000 LB. @ 45° MINIMUM
  - PROOF TESTED TO 125% (75,000 LB.) AND CERTIFIED
  - STANDARD SPECIFICATION # EAD21000A APPLIES
  - FINISH: SANDBLAST AND PRIME AND PAINT YELLOW
  - CALCULATED WEIGHT: 390 LB. SPREADER WITH SLING: 738 LB.
  - DESIGNED AND MANUFACTURED TO MEET OR EXCEED ASME B30.20 AND BTH-1, DESIGN CATEGORY B, SERVICE CLASS 0.

\*\* DO NOT SIGN IF CHANGES ARE REQUIRED \*\*  
 CUSTOMER APPROVAL: \_\_\_\_\_  
 DATE: \_\_\_\_\_

<small>1 1/2" DIMENSIONS APPLICABLE UNLESS OTHERWISE NOTED. DIMENSIONS ARE IN INCHES &amp; TOLERANCES ARE:        .XX ±.01 .XXX ±.005 .XXX ±.01</small>	<small>1" DIMENSIONS APPLICABLE UNLESS MAX. CLOSING TH. IS:        0 TO 4" ±.01 4.01" TO 7" ±.02 7.01" TO 10.5" ±.02 OVER 10.5" ±.02</small>	
<small>THIS DOCUMENT CONTAINS THE PROPRIETARY INFORMATION OF TANDEMLOC, INC. REPRODUCTION OR DISTRIBUTION WITHOUT THE WRITTEN APPROVAL OF TANDEMLOC, INC. IS EXPRESSLY PROHIBITED.</small>	<small>APPROVALS</small> <small>DATE</small> <small>03-19-19</small>	
<small>TITLE</small> <b>AT14A060-120-PA 78"-120" TELESCOPIC SPREADER</b>		<small>REV. DATE CODE</small> <b>D 65059 SAT14A060-120-PA</b>
<small>SCALE</small>		<small>REV. DATE CODE</small> <small>1 OF 1</small>